

A Different Maths for the 21st Century: Bubble and Arrow Diagrams show the answers to WHY, WHAT and HOW questions

Peter Osmon

Department of Education and Professional Studies, Kings College London

This work is part of an investigation of an alternative maths curriculum that emphasises 21st Century applications. It has never been more important to develop children's powers of reasoning and discussion and maths can help. The answers to Why, What and How questions are descriptions- causal, classification, and operational respectively- and they can all be represented as directed graphs. Causal graphs, where the nodes represent occurrences, are not as familiar as classification or algorithm graphs. Besides recording the past- why things (including beliefs) occurred- causal graphs can capture predictions about the future. These graphs can be realised in the classroom as bubble and arrow diagrams and used to develop and communicate answers to all three kinds of question.

Keywords: Mathematics; Curriculum; Why; What; How; Causal; Bubble and Arrow.

Introduction and Rationale

In this paper I explore an area somewhat outside the conventional maths curriculum in the belief that it is highly relevant for life in the 21st Century and in the hope that it has potential for interesting school children who are not "turned on" by more familiar maths. I propose that the answers to everyday questions beginning

Why, What, How, Which, When, Where,...

have characteristic mathematical forms and in this paper I focus on the first three, for reasons of limited space.

These kinds of questions are enquiries about knowledge (Sowa, 2000) and my discussion of the forms the answers can take aims to show how school mathematics can help in the appreciation and communication of various kinds of knowing. Traditionally the maths curriculum has emphasised argument and proof *within* mathematics rather than how mathematical types of argument can be applied more generally. I suggest it is time for school maths to become more outward looking.

The work reported in this paper is part of a wider investigation of an alternative maths curriculum.

My own background is an academic career spent in physics, electronics and computer science, as well as in innovation and management. My children have all passed through the state school system, with varying experiences of maths learning, and I was for many years a school governor and chair of governors. I have found the subject matter I introduce here helpful in these various contexts. Unfortunately I don't know any single source suitable for reference.

Overview of WHY, WHAT and HOW

In my experience people often have difficulty in effectively distinguishing these three kinds of questions and the kinds of answers they require. But making the distinction is necessary for reasoning in all kinds of contexts- everyday and professional.

Understanding these kinds of questions is sometimes complicated by variations in meaning. Thus, WHY might be asking about a physical *cause* or alternatively about a *purpose*. WHAT is asking for a description which might be a static *classification* or relationship or else a dynamic one, often in the form of an *algorithm*. HOW may be asking How do we know something? (*knowledge-How*) or How do we do something? (*operational-How*).

In a particular context meaning can also be complicated by the relationships among Why, What and How answers. Figure 1 is an example to demonstrate such relationships. Both WHAT questions are asking for a description. The first WHAT question is a static query- and is answered by a classification. The second WHAT question asks directly for an algorithm. The HOW question is an Operational-How and the answer says- follow that procedure.

NB Answers to both the second WHAT and the HOW refer to an Exclusion Algorithm. But these references are very different- the answer to WHAT is concerned with a description of the algorithm whereas the HOW answer is about its use. And use of an algorithm changes something in the world- in this case the status of a student.

Clarity of thought and reasoning requires being able to see and work with the kinds of distinctions brought out by this example. As always, when aiming to understand the general cases, there is no substitute for practice with examples. The exclusion example was deliberately presented in a simple question and answer way. It clearly invites probing with further questions. I will demonstrate the value of bubble and arrow diagrams in developing and communicating deeper answers to Why, What and How questions and hence developing powers of reasoning and I suggest that the process of developing such answers lends itself to group learning.

WHY, WHAT and HOW Answers and Directed Graphs

Directed graphs can represent the structural content of the answers to all three kinds of question.

Classification graphs convey answers to “What? Questions

Some classification graphs already feature in the curriculum- family trees and trees showing the classification of living things. (While tree-shaped classification graphs are common, they are not the only kind. The periodic table of the elements for example when represented as a graph has a pattern of interconnections that follow the underlying atomic structure.) Syntax graphs and expression graphs are less familiar tree-shaped examples but are more interesting mathematically because they can have dynamic interpretation- that is they can be traversed/executed- in the former case when a sentence is spoken and in the latter when an expression is evaluated.

Algorithmic graphs convey answers to “Operational-How?” questions

Algorithms also feature in the curriculum but directed graph representation of algorithms is perhaps less familiar. An algorithm describes the procedure for performing a process. A process is an ordered set of tasks and the steps in the algorithm correspond to performance of the individual tasks. (The mathematical significance of a task is that doing it changes a value.) It seems natural to map the steps of the algorithm onto the nodes of a directed graph with the links between the nodes showing the order of doing the tasks. The tasks may be only partially ordered however- either because some tasks are alternatives or because it is possible to perform some tasks concurrently- and links need to be labelled to distinguish these cases. Algorithms themselves are static- and like classification graphs they are descriptions- and also like some classification graphs they have a dynamic aspect- the processes they describe can be performed.

Causal graphs convey answers to “Why?” questions

Causal graphs are probably less familiar than either the classification graphs or the algorithmic graphs discussed in the two preceding sections and so they are discussed at greater length. While reading this section, it may be helpful to refer to the figures which show example causal graph fragments, drawn as bubble and arrow diagrams.

Why questions relate to occurrences- happenings- with *cause-effect relationships*. Thus-

Q: WHY did the First World War start?

Ie. This was the effect, what was the cause?

A: Because Archduke Franz Ferdinand was assassinated

Ie. This was the cause of that effect

The answer to a Why question may begin either- “Because...” if the question is looking backwards in time or- “Consequently...” if the question is looking forwards in time-

Q: WHY am I taking these exams?

Ie. This is a cause, what will be its effect?

A: Consequently I shall become a doctor

Ie. This is the effect I want from the cause

Both examples are likely to trigger further questions- “Why was he assassinated?”, “Why do I want to be a doctor?”- in which an occurrence which was an effect is seen to be a cause of further effects. These connected causes and effects can be represented as causal graphs where the nodes are occurrences and the links represent causal connections among them.

An effect can have multiple causes-

We say an effect D occurs “Because of A, B, C, ...”

And an occurrence may be the cause of more than one effect-

We say effects B, C, ... occur “Because of A”.

Causal graphs have probably been invented and reinvented many times. The earliest reference I have found is to the work of Frank and Lillian Gilbreth in the early 1900s mentioned in (Wolfram 2002).

We can distinguish *physical* causes (as in Figure 2.) from *sensate* causes where there is an intent to cause an effect, as in the two examples on the previous page. Physical causes are discussed at length by Bungay (Bungay 1979).

A cause necessarily precedes its effects. (The duration of occurrences varies and so a long duration cause may completely overlap in time its short duration effect.) And association of occurrences need not imply a cause-effect relationship. For example thunder and lightning have a common cause and the lightning is seen before the associated thunder is heard because the speed of light is greater than the speed of sound.

Causal graphs don't have cycles. But sometimes causal graphs are envisaged with cycles- for example to represent repeating cycles of infections- as with cholera infection and contaminated drinking water. The cycles are "shorthand" for a succession- infinite succession if nothing is done to stop repeated causation- of similar cause-effect chains of occurrences.

Causal graphs are used to model answers to the why questions that arise in a great variety of real-world contexts- scientific, medical, technological, sociological, personal... These graphs can be very large and elaborate- with probabilities and triggering thresholds assigned to occurrences. But relatively simple graphs can capture essential causal reasoning at secondary school level in aspects of economics, geography, history, science, sociology, as well as everyday problems.

Bubble and Arrow Diagrams

Directed graphs are a mathematical abstraction. Bubble and arrow diagrams are a convenient physical realization of all three kinds described in this paper- particularly convenient in the classroom where they can be drawn with pencil and paper or on a computer screen using a drawing package.

Our pattern recognition abilities are such that most people find bubble and arrow diagrams, providing they are not too crowded ("rule of seven"- maximum of seven bubbles on a page), more effective than plain text for communicating structural information. I am not claiming that people think directly in these notations- rather they are good for communicating the results of thinking- to ourselves and to others.

Figures 2, 3, 4 show some causal graph fragments in bubble and arrow form. Like the more familiar algorithm graphs, fragments of causal graphs, like these, can be connected to show more of a causal history.

Developing a causal diagram for a real-world situation is a *modelling* exercise. Since "everything in the real-world is connected to everything else" and "we shouldn't bite off more than we can chew", it is necessary to decouple the part we are interested in from the whole. For example, it would undoubtedly be interesting to draw a diagram for the causes of World War 1- which are discussed in all history textbooks I have ever seen. But the story extends right back through European history and so diagramming it may be infeasible, simply because of the scale of the task. However it probably is feasible to diagram the causes of the actual outbreak of war- assassination of Franz Ferdinand, various treaty obligations among the nations, troop mobilisations, etc.

The similar syntax of the three kinds of bubble and arrow diagrams conceals their three very different meanings. In causal diagrams the bubbles represent

occurrences. In algorithm diagrams the bubbles represent steps. In classification diagrams the bubbles represent sub-classes or class instances.

Conclusions

Mathematics has more to offer learners than the traditional curriculum admits. A whole dimension has been missing from maths education, namely the use of mathematical thinking and notation to clarify real-world problems and issues that often may be scarcely formulated.

For many people this knowledge would be as helpful as numeracy, in both their private and professional lives. And I suggest the complexity of 21st Century life makes *developing* it for learning in schools an urgent educational task.

In this paper I have chosen WHY, WHAT and HOW questions and their answers as exemplars of wider mathematical thinking. These questions can all be answered by constructing bubble and arrow diagrams- albeit with distinct interpretations. Classification and algorithm diagrams, for answering WHAT and HOW questions, are relatively familiar and so I have given most space to the meaning and construction of causal diagrams for answering WHY questions. Bubble and arrow diagrams are a good medium for communicating both developing and completed answers to these kinds of questions and a special advantage is that they are very well suited to group working.

I am optimistic that this neglected facet of mathematics learning has the potential to capture the interest of the many children (and their teachers) for whom maths has been anathema. We shall see.

References

- Bungay, Mario 1979 Causality and Modern Science, New York; Dover Publications.
Sowa, John F. 2000 Knowledge Representation: Logical, Philosophical and Computational Foundations, Pacific Grove; Brooks Cole
Wolfram, Stephen 2002 A New Kind of Science, 1032, Champaign, Wolfram Media

Q: WHY do we have an exclusion policy?
 Ie For what purpose?
 A: To comply with regulations of the Education Authority

Q: WHAT is the policy on exclusions?
 A: *Classification* of the circumstances which warrant a student's exclusion is as follows...

Q: WHAT is the exclusion procedure?
 A: It's an *algorithm* in the Governance Handbook

Q: HOW do I exclude someone?
 A: You perform the exclusion process
 Ie You follow the procedure given in the Handbook

Figure 1.
 Example WHY, WHAT, HOW
 Questions and Answers

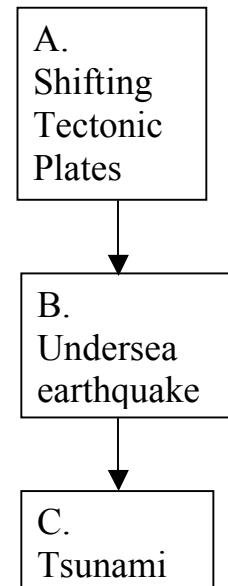

Figure 2.
 Causal chain-
 A causes B causes C

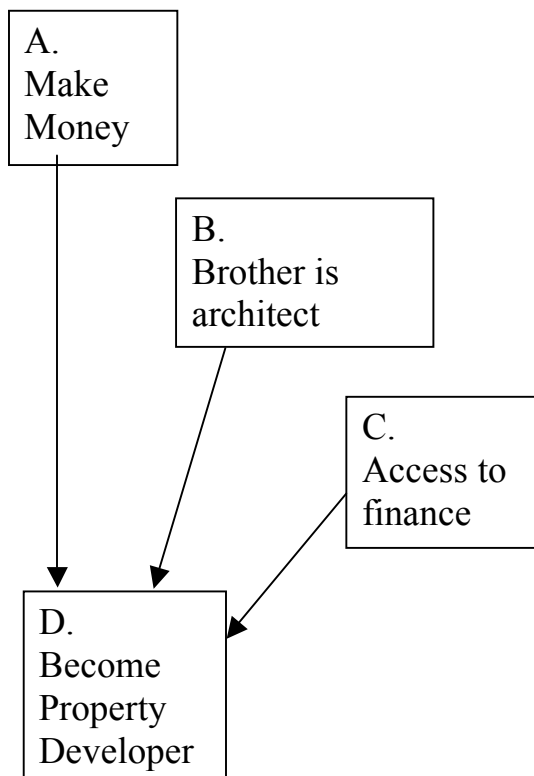

Figure 3.
 Multiple causes of an effect-
 (A, B, C) cause D

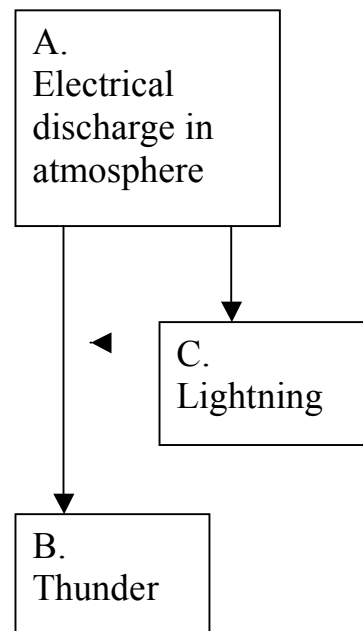

Figure 4.
 Two effects with a
 common cause-
 A causes (B, C)